

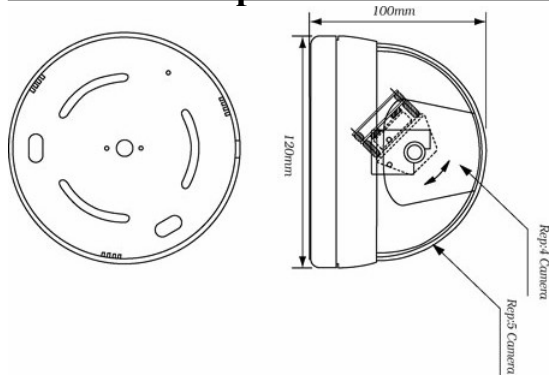

N5-108

HRES DOME VARIFOCAL AUTOIRIS VANDALPROOF

Installation Tips



1. Avoid places where there is direct sunlight.
2. Do not directly touch the CCD element. If necessary, use a soft cloth moistened with alcohol to wipe off the dust.
3. Avoid places where temperatures exceed 50° C or more
4. Avoid places where there is frequent vibrations or shocks
5. Please power with 24VAC/30VA transformer.
6. When any abnormalities occur, make sure to unplug the unit and contact your local dealer
7. Remove the cover, loosen up the two levers located around the lens by turning them counterclockwise, turn cylinders around the lens to adjust zoom and focus. Tight levers after reaching desired adjustment.

Specifications

POWER SOURCE	AC24V.60Hz
IMAGE PICK -UP DEVICE	1/3" SONY SUPER HAD CCD (NTSC) 768(H) x 494(V)
SCANNING SYSTEM.	2:1 INTERLACE 525LINES / 60FIELDS / 30FRAMES
VIDEO OUTPUT	1.0V (p-p) NTSC COMPOSITE
Mm. Illumination	0.7 LUX at F1.2 (AGC OFF)
RESOLUTION	More Than 480TV LINE (HORIZONTAL)
BACK LIGHT COMPENSATION	BUILT-IN (ON)
ELECTRONIC SHUTTER	1/60 ~ 1/100.000 sec
WHITE BALANCE	AWB
LENS	4~9 mm VARIFOCAL
AGC	BUILT-IN (ON)
S/N RATIO	MORE THAN 48dB (AGC OFF)
OPERATION TEMPERATURE	-10°C +50°C
WEIGHT	AC24V: 600g (BUILT IN LENS). DC12V: 550g(BUILT IN LENS)